

VIEW B
SCALE 1 : 5

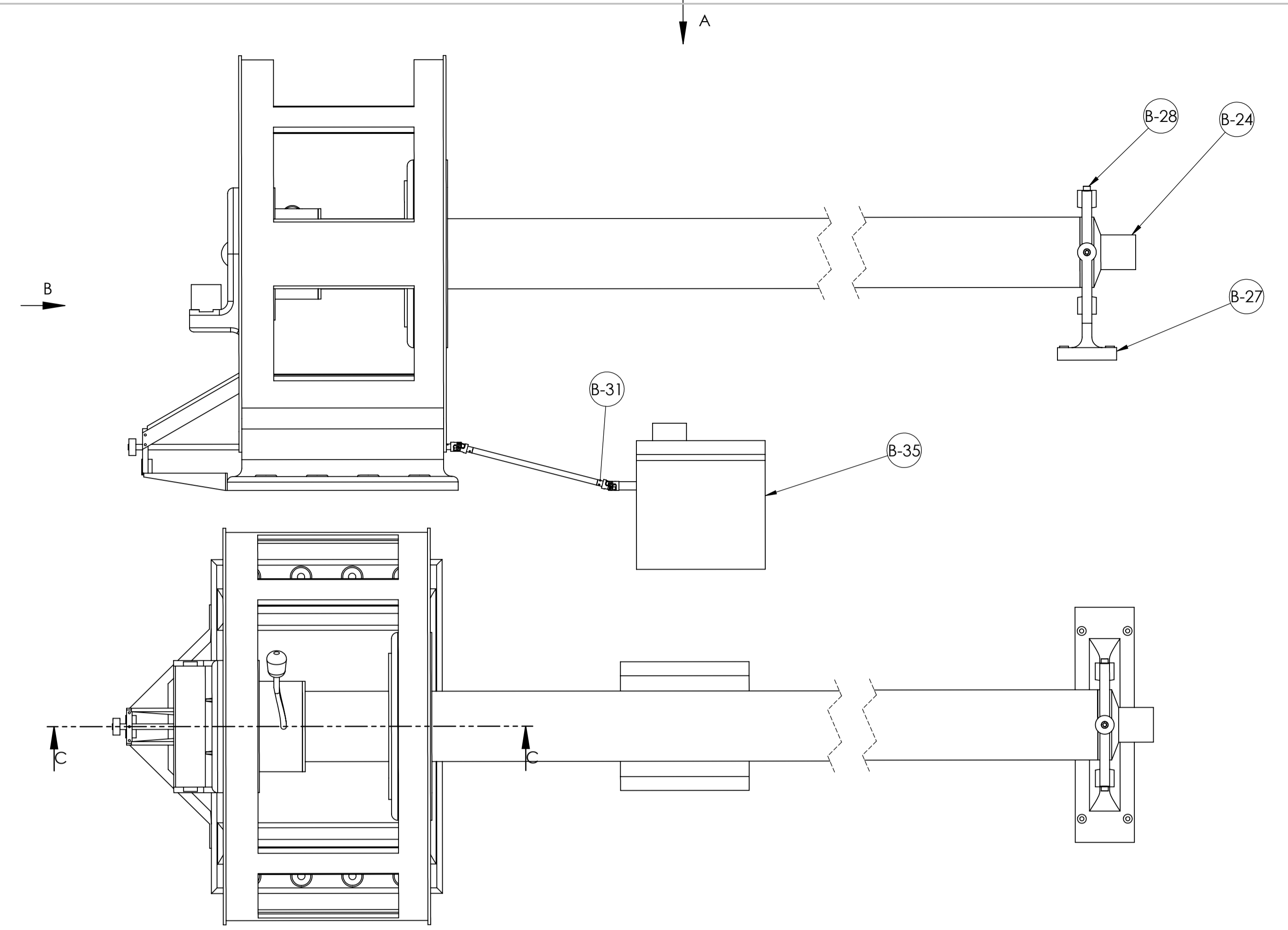

VIEW A
SCALE 1 : 5

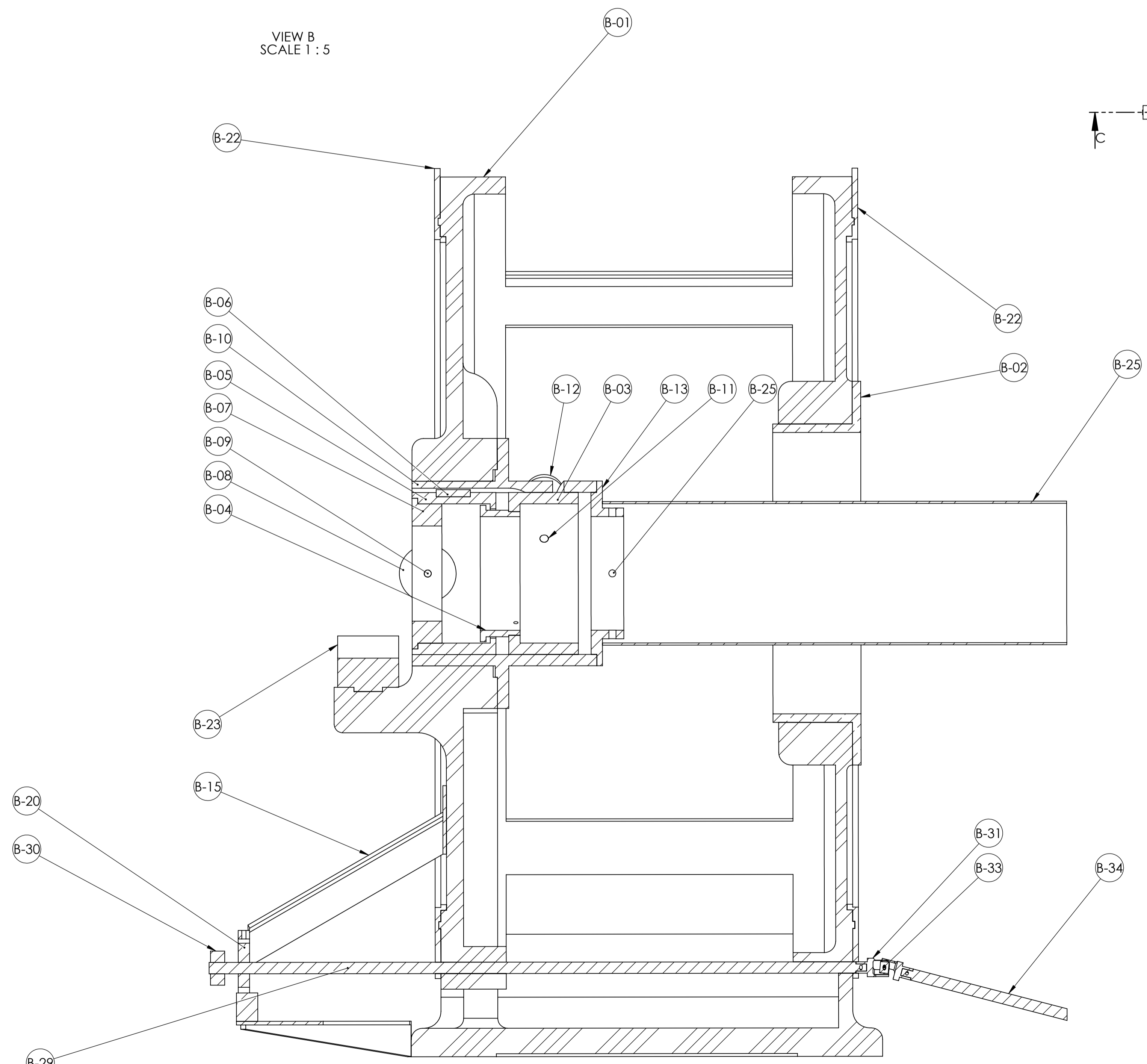

SECTION C-C
SCALE 1 : 2

ITEM NO.	PART NUMBER	DESCRIPTION	QTY.
B-01	Corpo do Suporte		1
B-02	Tampa Leste		1
B-03	Casquilho com furo		1
B-04	Casquilho		1
B-05	Casquilho final		1
B-06	Chaveta		1
B-07	Suporte dos roletes		1
B-08	Rolete		2
B-09	Pino dos roletes		2
B-10	Casquilho interior do suporte		1
B-11	Parafuso do manipulo		1
B-12	Maçaneta		1
B-13	Tampa do Sup da Munhoneira Oeste		1
B-14	T1		1
B-15	T2		1
B-16	T2b		1
B-17	T3		1
B-18	A		2
B-19	B		1
B-20	C		1
B-21	D		1
B-22	Discos nas munhoneiras com furo		2
B-23	Pista do eixo na munhoneira		1
B-24	CA_Peca 2		1
B-25	CA_Peca 1		1
B-26	CA_Peca 4		4
B-27	Munhoneira dos colimadores axiais		1
B-28	ISO 4762 M6 x 10 --- 10N		4
B-29	Veio		1
B-30	Roda dentada pequena		1
B-31	cardan1		4
B-32	cardan2		2
B-33	umbraco		5
B-34	Veio 2		1
B-35	Motor eléctrico do eixo		1

UNLESS OTHERWISE SPECIFIED:
DIMENSIONS ARE IN MILLIMETERS
SURFACE FINISH:
TOLERANCES:
LINEAR:
ANGULAR:

FINISH: _____
DEBUR AND BREAK SHARP EDGES

DO NOT SCALE DRAWING

REVISION

NO.	NAME	SIGNATURE	DATE	TITLE

MATERIAL: _____
WEIGHT: _____

SCALE: 1:20

SHEET 1 OF 1